

# VP 1000

Water Driven  
Gas Freeing Fan



## Victor Marine

### Description

The VP1000 is a high performance, deep penetration, water driven fan, constructed using high grade 316 stainless steel. This non-sparking fan is suitable for use on all types of vessels. It provides gas freeing to allow for change of cargo, through to providing health & safety requirements and tank maintenance

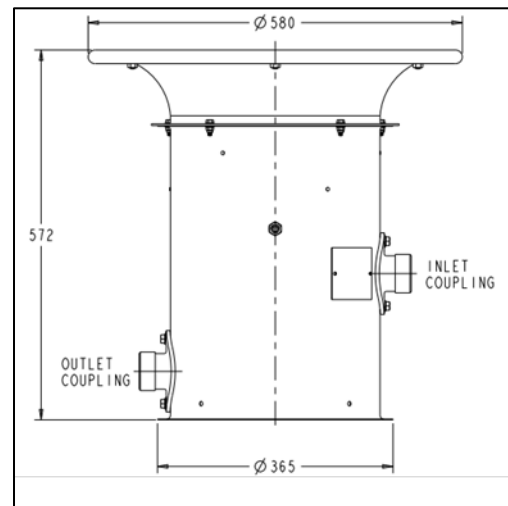

### Key Features

- Designed and Class Approved for use in hazardous areas
- Supply or Extract mode by simple reversal of water supply
- Integral 'Direct In-Line' drive; no gearbox to maintain or fail
- Non-Sparking (ATEX approved)
- Can operate at low pressures
- Can be supplied for horizontal mounting
- High airflow throughput
- High static pressure
- Efficient motors
- Marine grade materials
- Fail-safe bleed tube to indicate seal failure
- Fully Type Approved by Class Societies worldwide

### Technical Information

Drive media	Water
Max height	572mm
Max width	345mm
Weight	27kg
Water Connection	Multiple options available
Max Air Flow	10540m <sup>3</sup> /hr
Max Static Pressure	1790Pa
Max Water Flow Requirement	27.0m <sup>3</sup> /hr
Operating Pressures	2.0 – 12.0 kg/cm <sup>2</sup> Optimum
Deck Opening	To suit standard Ø318mm



Globally focussed on cleaner solutions

# VP 1000

Water Driven  
Gas Freeing Fan



# Victor Marine

## PRODUCT DIMENSIONS:

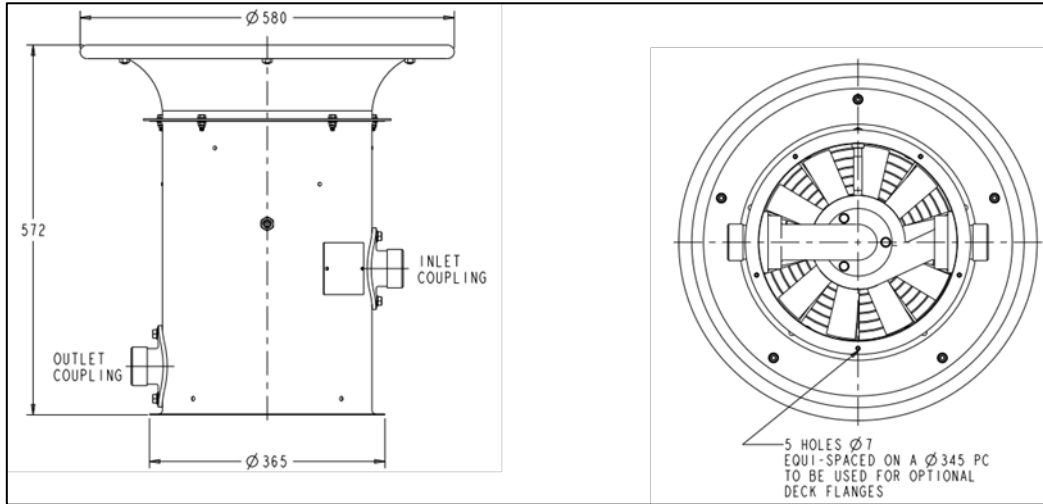

## PERFORMANCE GRAPHS:

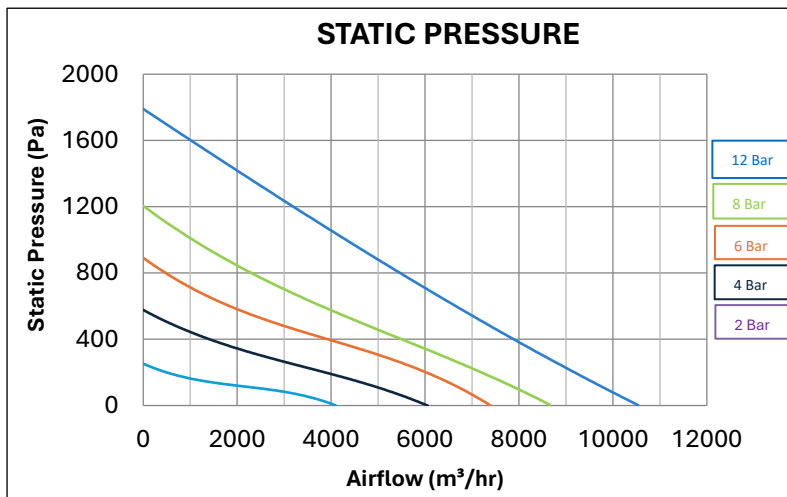
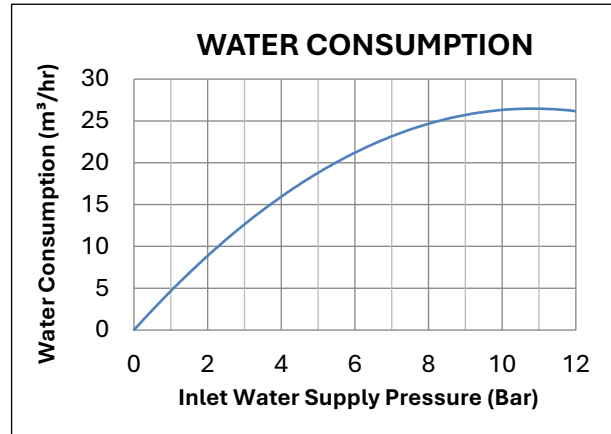
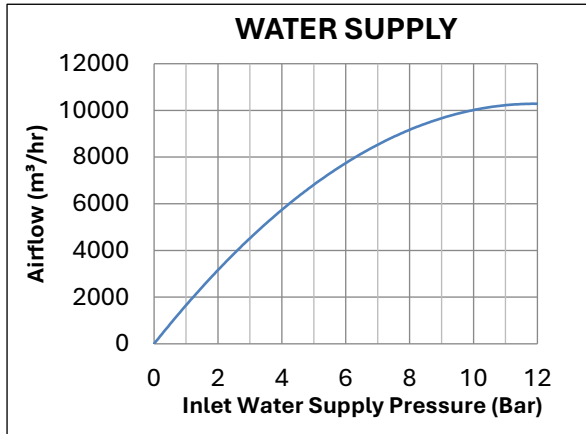

Victor Marine Limited, Unit 7, Waterloo Court, Markham Vale, Chesterfield, S44 5HN